

WEIL-McLAIN

Wm

HE II Hot Surface Ignition (HSI)

Gas
Control
Supplement

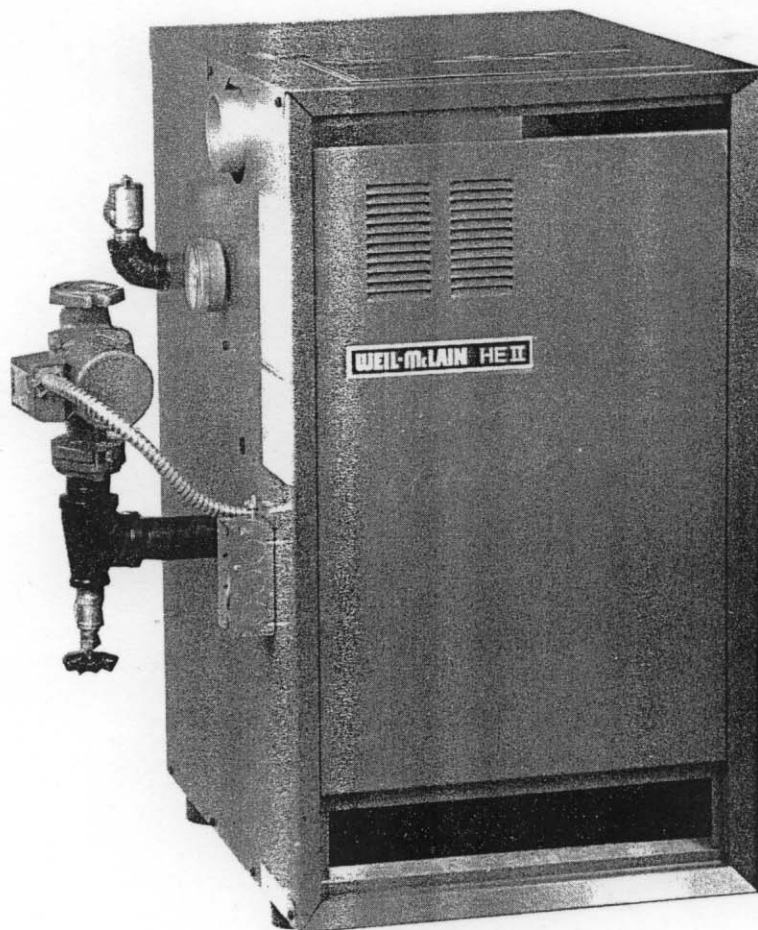

For Natural or Propane Gas-Fired Boilers

TO THE USER: Gas Control Supplement is to be used by a qualified service technician.

Part Number 550-141-565/0691DCP



Table of Contents

Section A: Sequence of Operation 4-5

Section B: Troubleshooting 6-10

Section C: Parts 11

IMPORTANT: When calling or writing about the boiler, PLEASE GIVE THE MODEL listed on the boiler rating label AND THE CP NUMBER found next to the rating label.

RATING LABEL AND
CP NUMBER
(ON JACKET
LEFT PANEL)

BLOWER MOTOR

LIMIT CONTROL

CIRCULATOR

TRANSFORMER

ROLLOUT
THERMAL
FUSE ELEMENT

IGNITOR

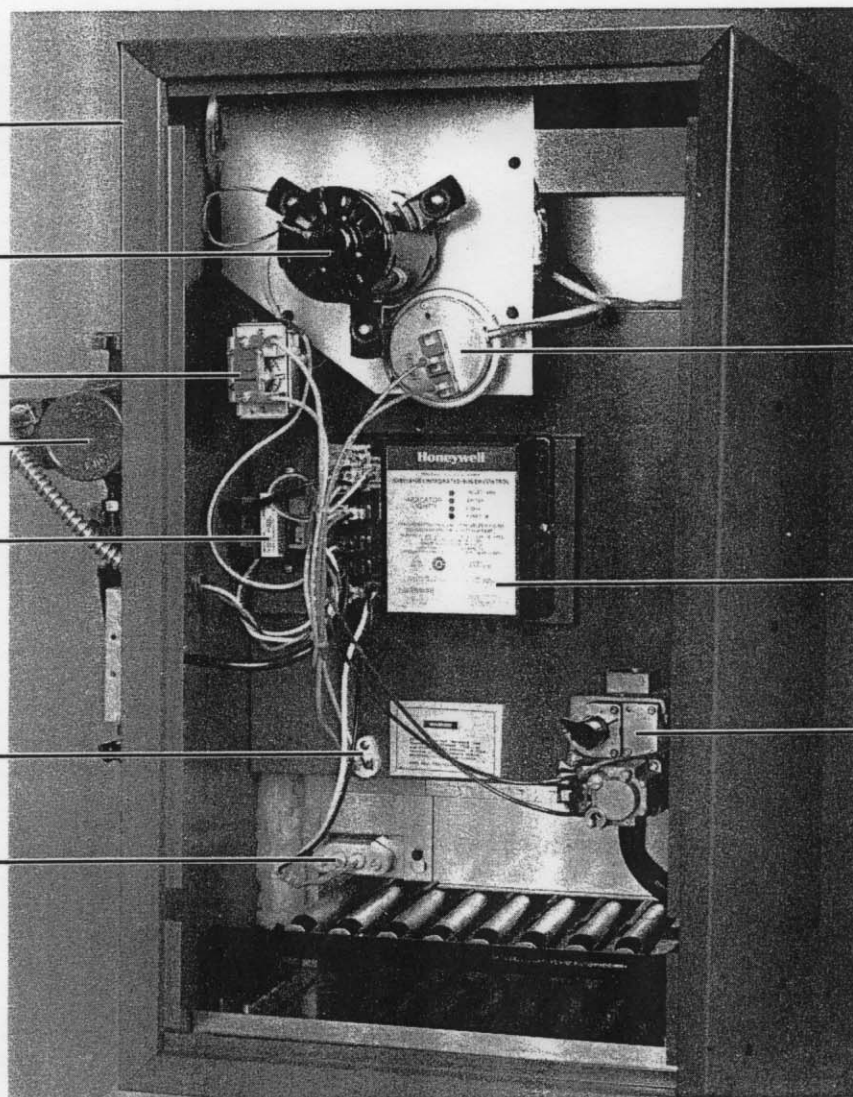

AIR PRESSURE SWITCH

CONTROL MODULE

GAS VALVE



Section A: Sequence of Operation

SEQUENCE OF OPERATION:

Use chart below and observe indicator lights located on control module.

STEPS (After step #8 is completed, boiler goes back to Standby, Step #1)	Call For Heat	Indicator Lights				Timing
		Power	Purge	Ignitor	Vlv/Flm	
1. Standby • Waiting for call for heat	NO	●	○	○	○	—
2. Start Cycle • Circulator on • Blower on	YES	●	○	○	○	—
3. Pre-Purge • Air pressure switch contacts closed • Air flow proven	YES	●	●	○	○	15 sec
4. Ignitor • Ignitor on • Ignitor heating	YES	●	○	●	○	20 sec
5. Gas Valve • Gas valve open • Ignitor remains on	YES	●	○	●	●	2 sec
6. Proving Flame • Ignitor off • Gas remains on	YES	●	○	○	●	4 sec
7. Flame* • Flame proven • Boiler producing heat	YES	●	○	○	●	—
8. Post-Purge • Circulator off • Blower remains on	NO	●	●	○	○	30 sec

* If flame is not proven in 4 seconds, boiler recycles 2 times to retry for ignition before going into lockout. Recycle ignitor timing is 30 seconds.

● Indicator light ON.

○ Indicator light OFF.

SCHEMATIC WIRING

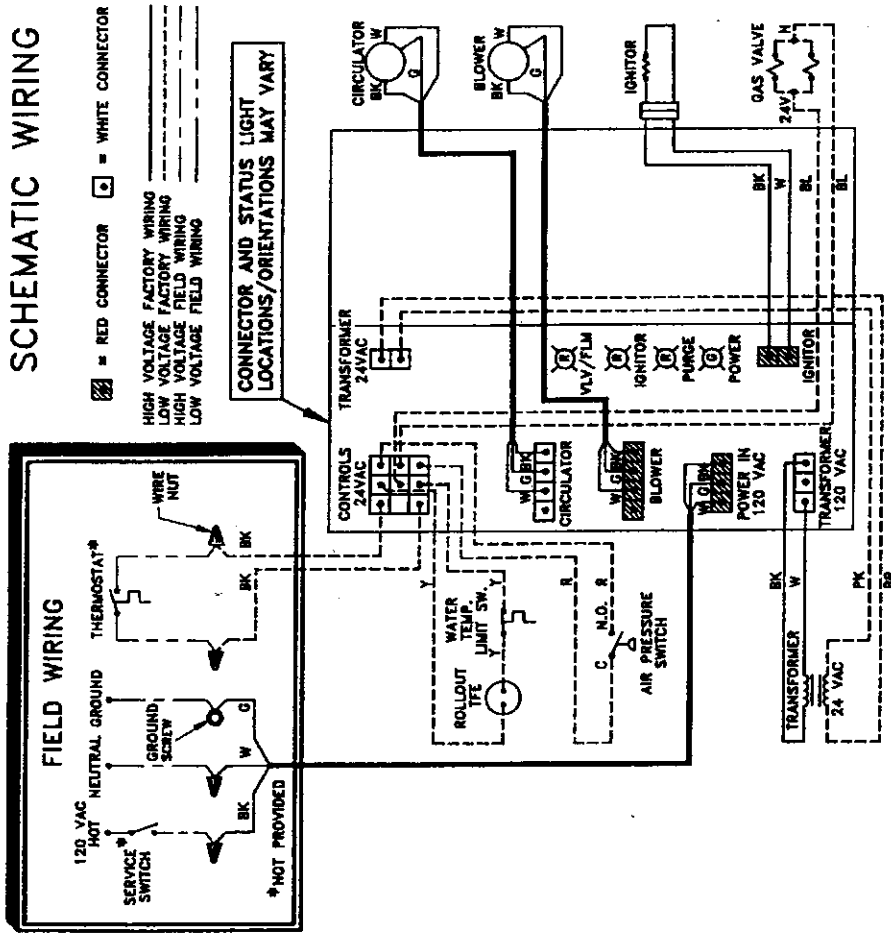

CONNECTOR AND STATUS LIGHT LOCATIONS/ORIENTATIONS MAY VARY

LADDER WIRING

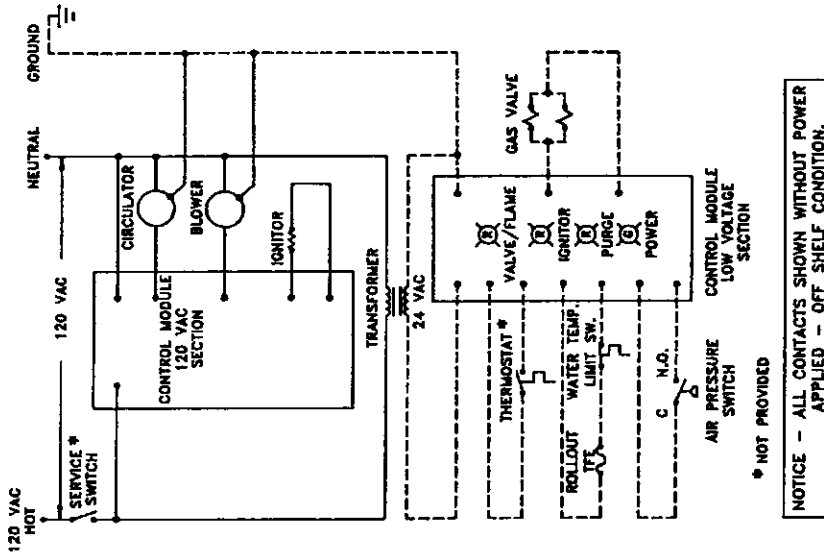

NOTICE - ALL CONTACTS SHOWN WITHOUT POWER APPLIED - OFF SHELF CONDITION.

WARNING

ELECTRICAL SHOCK HAZARD, CAN CAUSE SEVERE INJURY OR DEATH. DISCONNECT POWER BEFORE INSTALLING AND/OR SERVICING.

NOTES:

- ALL WIRING MUST BE INSTALLED IN ACCORDANCE WITH:
 - U.S.A. - N.E.C. AND ANY OTHER NATIONAL, STATE, OR LOCAL CODE REQUIREMENTS HAVING JURISDICTION.
 - CANADA - C.S.A., C22.1 C.E.C. PART 1 AND ANY OTHER NATIONAL, PROVINCIAL, OR LOCAL CODE REQUIREMENTS HAVING JURISDICTION.
- ALL SAFETY CIRCUIT WIRING MUST BE:
 - U.S.A. - N.E.C. CLASS 1.
 - CANADA - C.S.A. C22.1 C.E.C. PART 1.
- THERMOSTAT ANTICIPATOR SETTING (SINGLE ZONE): SEE LABEL ON CONTROL MODULE.
- IF ORIGINAL ROLLOUT TFE WIRE AS SUPPLIED WITH THE APPLIANCE MUST BE REPLACED, TYPE 200°C WIRE OR ITS EQUIVALENT MUST BE USED. IF ANY OTHER ORIGINAL WIRE AS SUPPLIED WITH THE APPLIANCE MUST BE REPLACED, TYPE 90°C WIRE OR ITS EQUIVALENT MUST BE USED.
- FOR MULTIPLE ZONING USE EITHER ZONE VALVES OR CIRCULATORS. REFER TO THE COMPONENT MANUFACTURER'S INSTRUCTIONS FOR APPLICATION AND WIRING.
- REFER TO CONTROL COMPONENT INSTRUCTIONS PACKED WITH THE BOILER FOR APPLICATION INFORMATION.

WIRING DIAGRAM FOR HE II (SERIES 1)
 • INTEGRATED BOILER CONTROL SYSTEM
 • NATURAL OR PROPANE GAS BOILERS
 • FORCED HOT WATER

WEIL-McLAIN
 A Division of The Marley Company
 Michigan City, Indiana 46360
 PART NUMBER 550-224-053/0691WM

Section B: Troubleshooting

TROUBLESHOOTING PROCEDURE:

DANGER

Never jumper (bypass) rollout thermal fuse element or any other safety device except for momentary testing as outlined in Troubleshooting Charts. A fire or explosion causing substantial property damage and/or severe personal injury will result.

CAUTION

Burner access panel must be in position during boiler operation to prevent momentary flame rollout on ignition of main flame, which can melt rollout thermal fuse. Minor property damage can result.

1. Before troubleshooting:
 - a. Have a voltmeter that can check 120VAC and 24VAC and a continuity checker.
 - b. Check for 120VAC (min. 102-max.132) to boiler.
 - c. Have an inclined manometer with 0-2" W.C. range.
 - d. Make sure thermostat is calling for heat and contacts (including appropriate zone controls) are closed. Check for 24VAC between thermostat wire nuts and ground.
2. Check the following:
 - a. Wire connectors to control module are securely plugged in at module and originating control.
 - b. Hoses are properly and securely plugged in and are not damaged.
3. Check gas pressures:
 - a. With boiler off:
 - 13" W.C. maximum natural or propane gas pressure upstream of gas valve.
 - b. With boiler on:
 - 5" W.C. minimum natural gas pressure or 11" W.C. propane upstream of gas valve.
 - 3-1/2" W.C. minimum natural gas pressure or 10" W.C. propane downstream tapping on gas valve. Can be adjusted by regulator on gas valve.

CHECKING AIR PRESSURE SWITCH:

NOTICE

Make sure boiler water temperature is 100°F. or cooler before starting procedure.

1. Remove red sensing tube at front of pressure switch (closest to you as you face the boiler).
2. Install a tee into sensing tube. Run another piece of tubing from the tee to the pressure switch.
3. Attach third leg of the tee to suction side of an inclined manometer.
4. Remove white sensing tube at rear of pressure switch.
5. Install a tee into sensing tube. Run another piece of tubing from the tee to the pressure switch.
6. Attach third leg of the tee to pressure side of the manometer.
7. Turn off manual main gas valve and set thermostat to call for heat. Blower will run but burners will not ignite.
8. Check for 24VAC between air pressure switch N.O. terminal and ground. Then check for 24VAC between air pressure switch common terminal and ground.
9. If manometer reading is higher than 1.5" W.C. and voltmeter readings in step #8 are not 24VAC each, replace air pressure switch.
10. If reading is lower than 1.5" W.C. check for possible causes:
 - Blockage in hoses or sensing tubes.
 - Obstruction in blower housing outlet.
 - Loose blower wheel on motor shaft.
 - Blower motor not at proper rpm.
 - Blower back plate not sealed properly.
 - Blockage in block assembly.
 - Blockage in flue pipe or termination.
 - Blockage in flue collector hood.
 - Dirt accumulation on flapper in transition.
11. When pressure reading is proper and air pressure switch is operating properly, remove tees and reinstall hoses to air pressure switch.

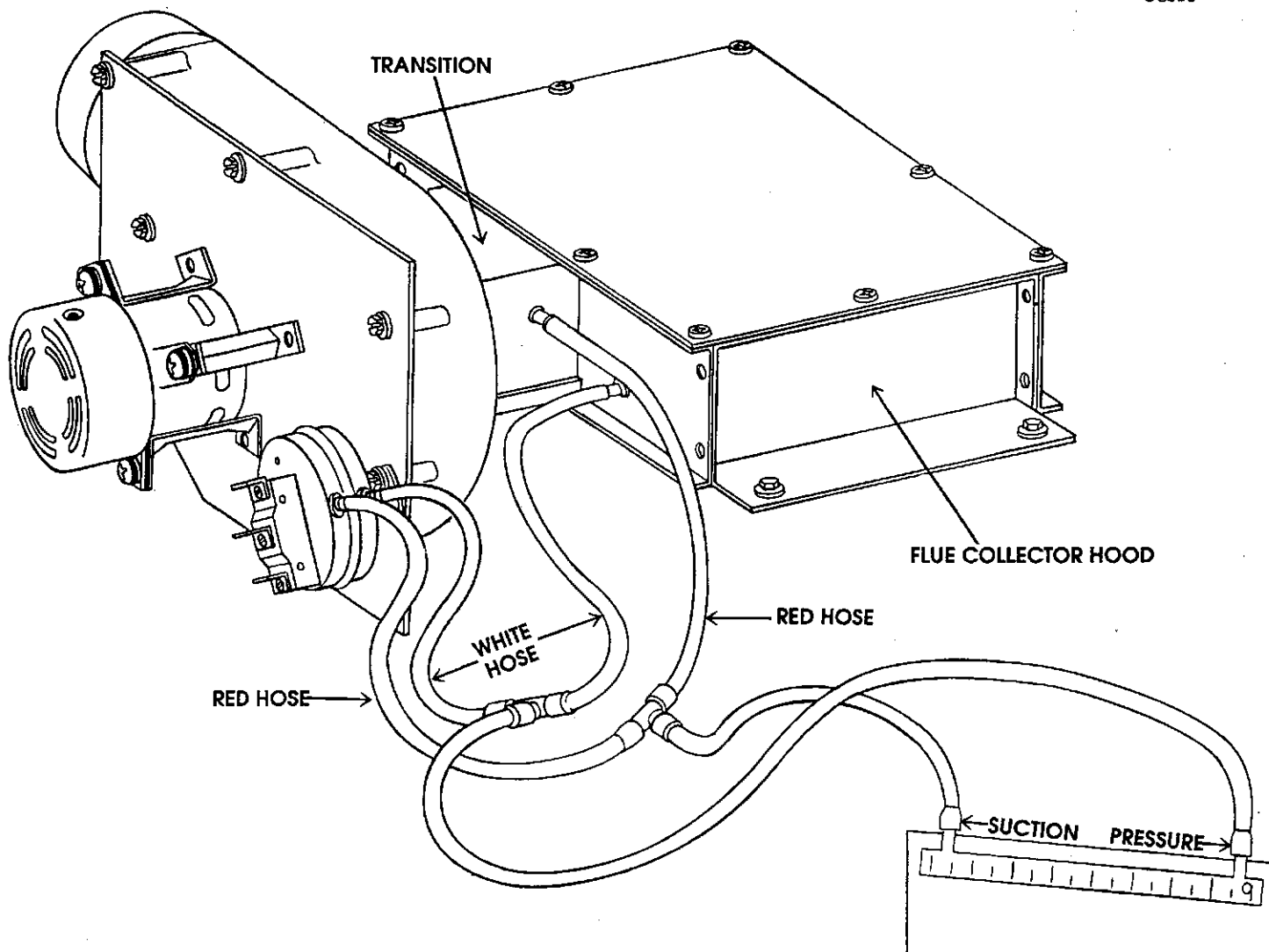

CHECKING AIR PRESSURE SWITCH
FIGURE 1

SPECIAL SERVICING TIPS:

1. Ignitor:

DANGER

Wait several minutes until ignitor cools down before attempting replacement. Failure to do so will cause severe personal injury.

Unplug from wiring harness and remove before servicing.

Ignitor is fragile - handle with care.

Attach ignitor and ignitor shield to ignitor bracket before installing.

2. Gas Valve:

Install gas valve so arrow on gas valve points in direction of gas flow.

3. Control Module:

Make sure ground wire is attached per wiring diagram. Good grounding is extremely important for proper operation.

CAUTION

Incorrect wiring or voltage from zone valves or 120VAC power can damage electronic components in control module and cause boiler to not operate. Solder or water splatter between plugs and circuit board can cause improper operation of control module.

CHART 1 - IS GREEN LIGHT OFF OR FLASHING - NOT ON STEADY?

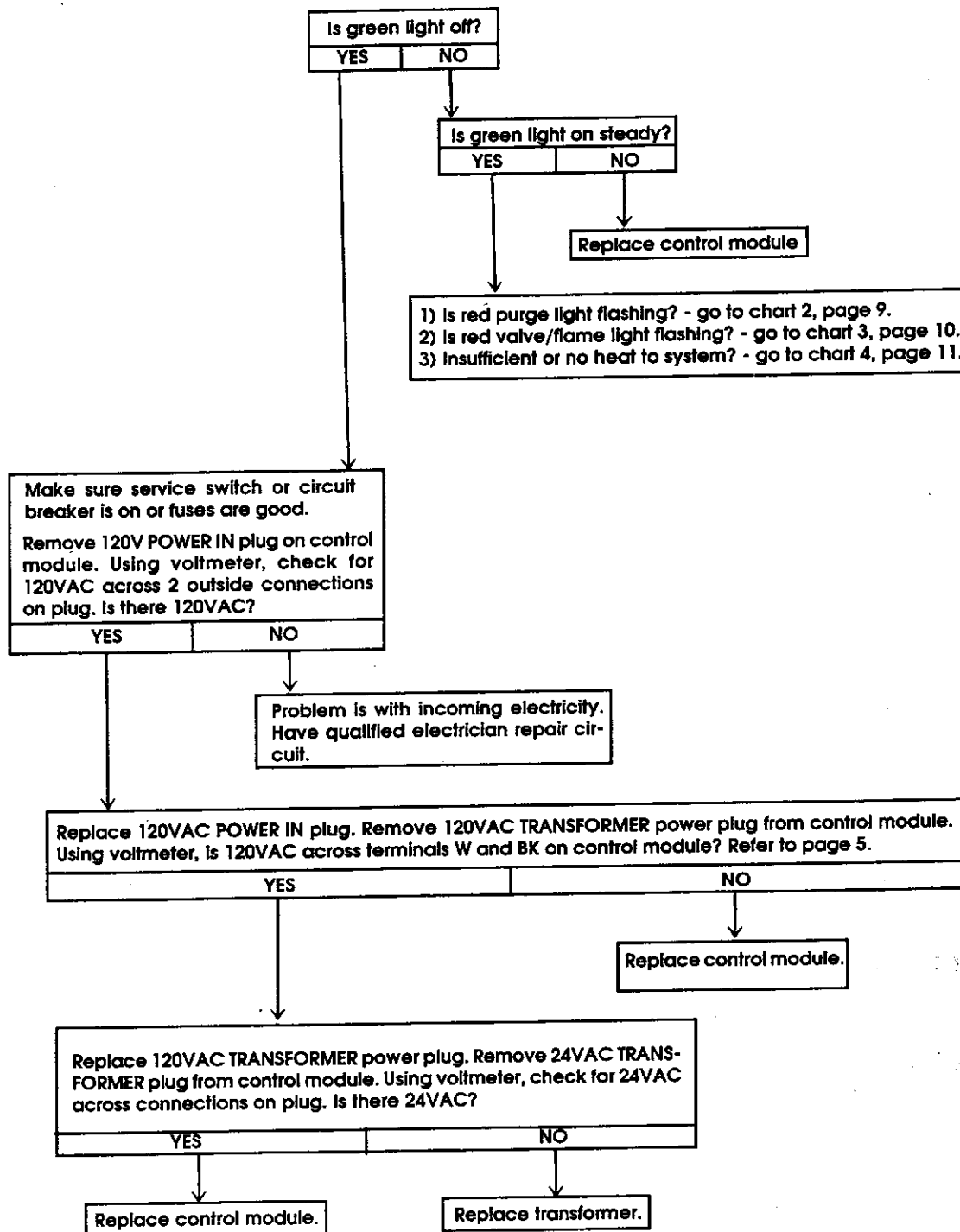

CHART 2 - IS RED PURGE LIGHT FLASHING?

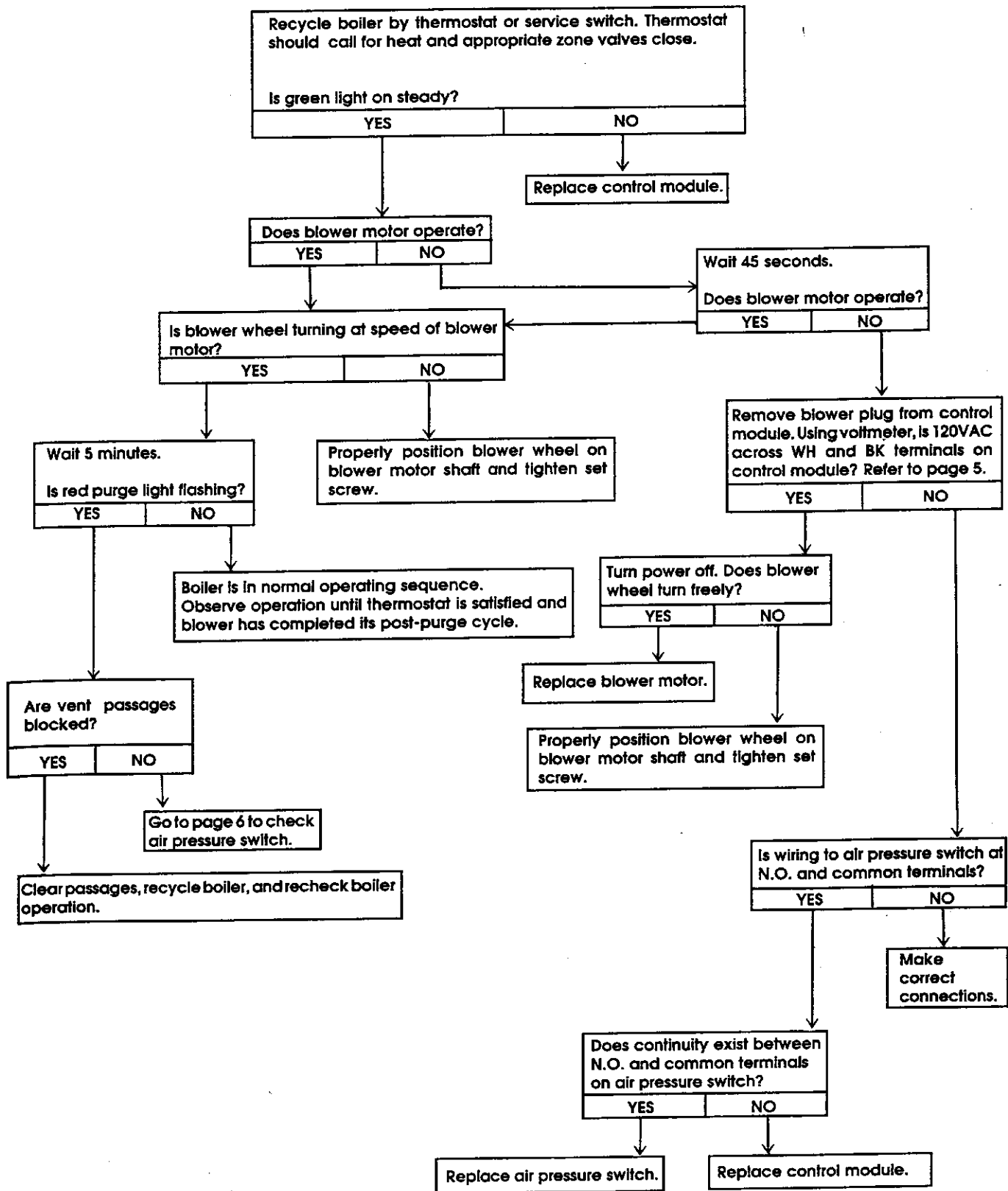

CHART 3 - IS RED VALVE/FLAME LIGHT FLASHING?

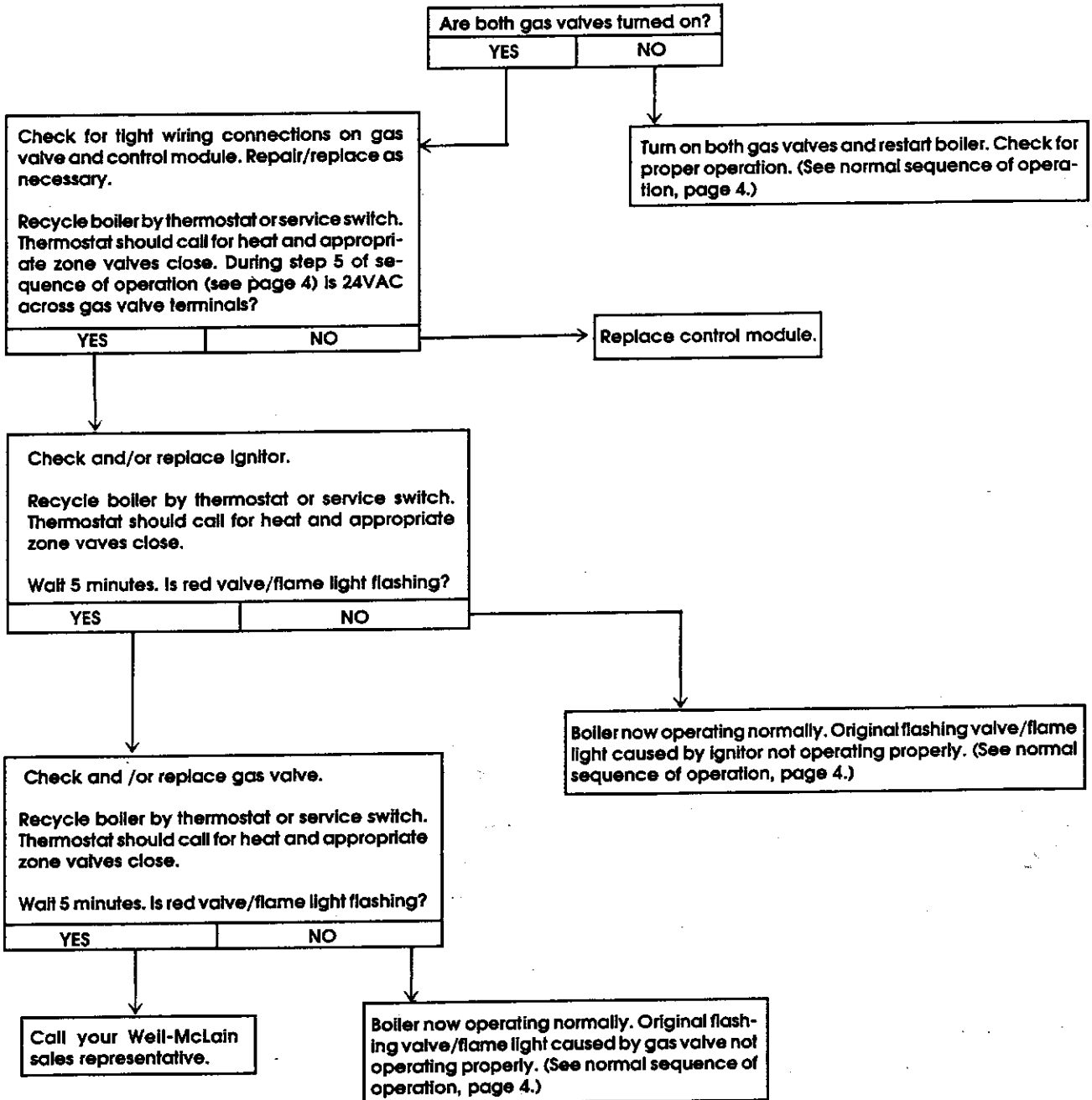
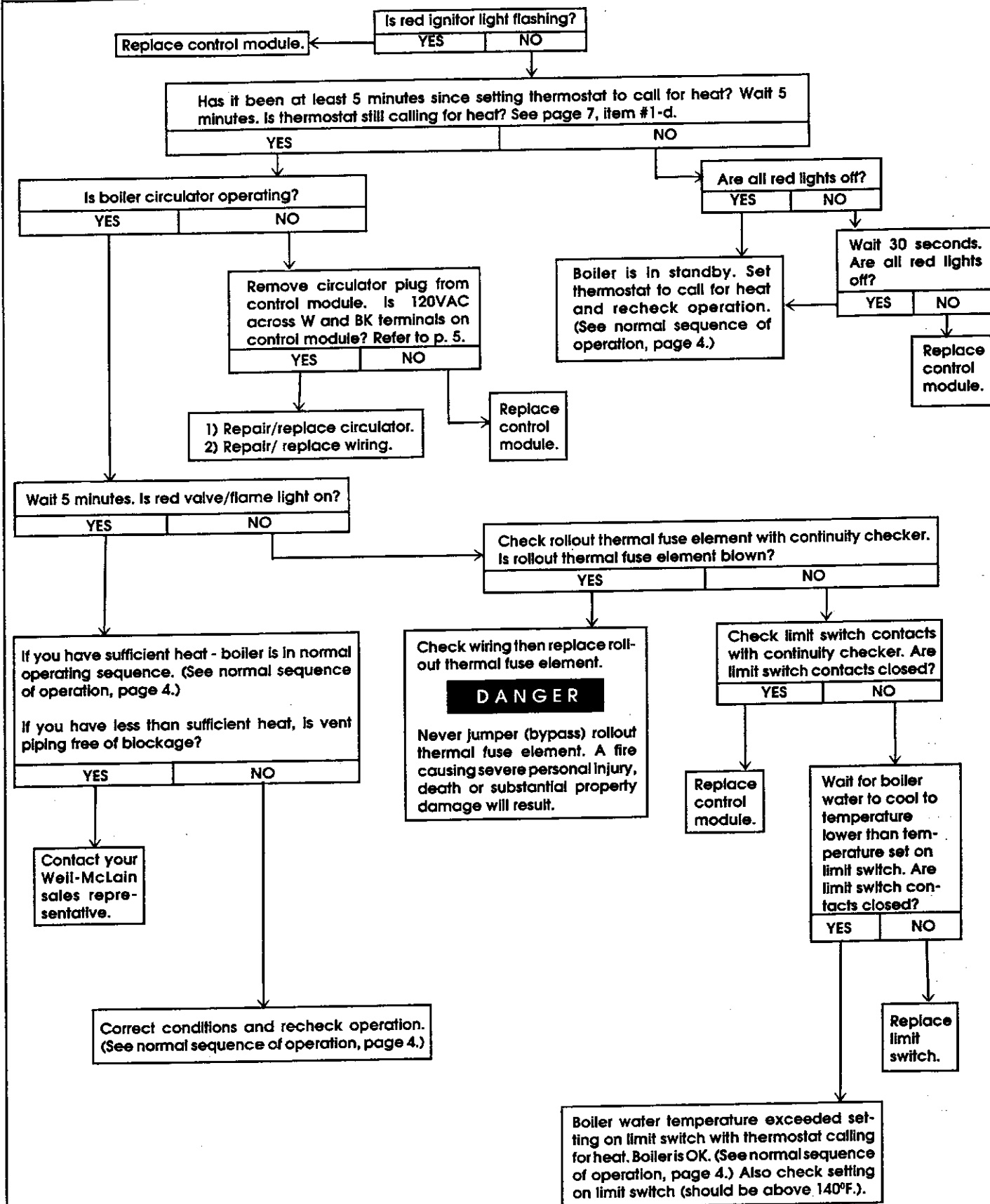

CHART 4 - INSUFFICIENT OR NO HEAT TO SYSTEM



Section C: Parts

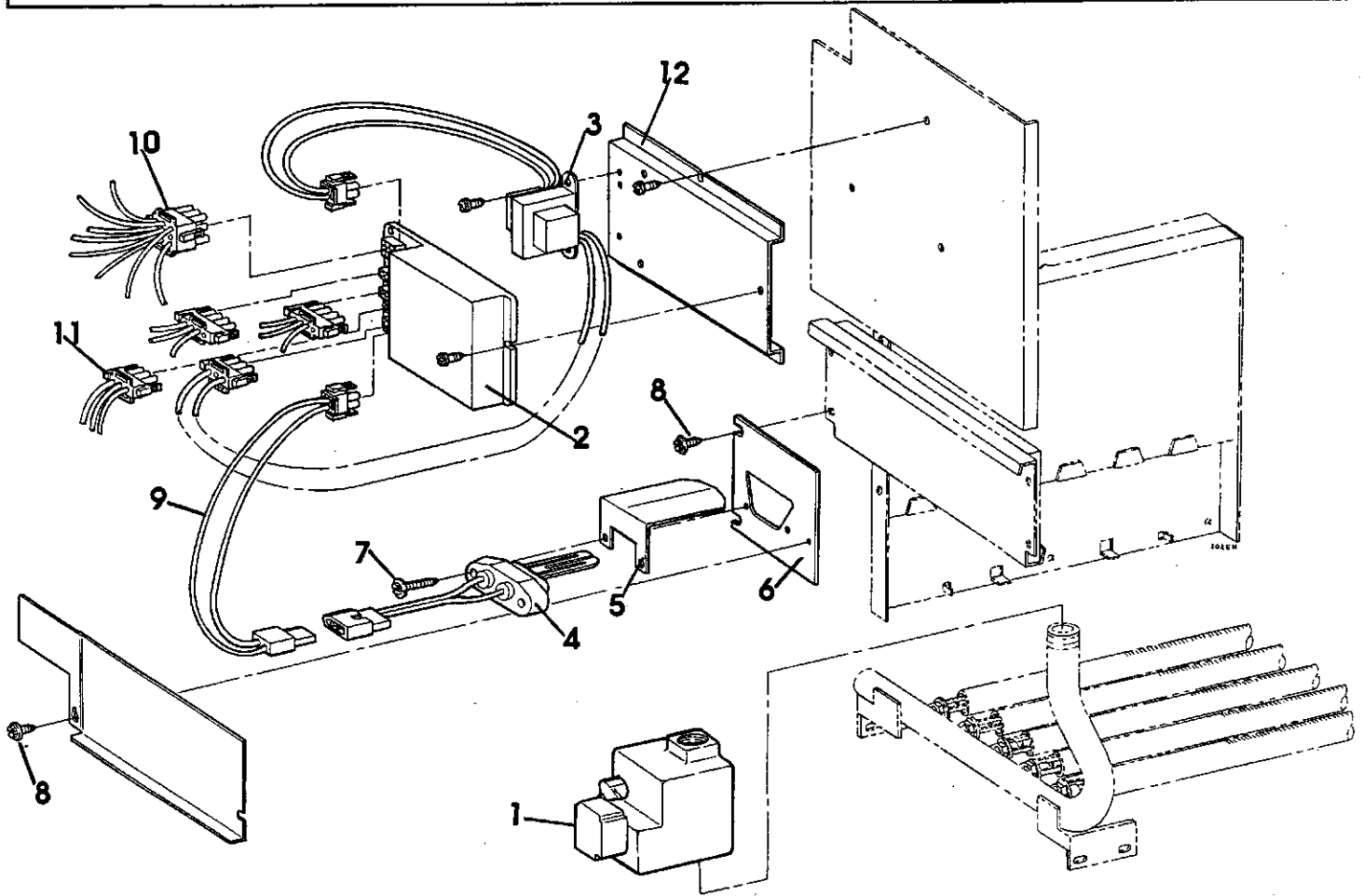

Figure No.	Description	Weil-McLain Sales Ref. No.			
		HE II-3	HE II-4	HE II-5	HE II-6
1	Gas Valve - Natural Propane	10C134	10C134	10C134	10C134
		10C135	10C135	10C135	10C135
2	Control Module Kit, Including: Module; Screws	10C400	10C400	10C400	10C400
3	Transformer	10C401	10C401	10C401	10C401
4	Ignitor Kit, Including: Ignitor; Shield; Gasket (not used with HE II); Screws	10C402	10C402	10C402	10C402
5	Ignitor Shield	10C449	10C449	10C449	10C449
6	Ignitor Bracket	10C450	10C450	10C450	10C450
7	Screw, Thd Forming Hex, Washer Hd, Slot, 10-32 x 1-1/4 ZP (Ignitor to Ignitor Bracket)	■	■	■	■
8	Screw, STP, Type 23SL Hex, Washer Hd, Black Phosphate & oil, 10-32 x 3/8 (Access Panel to Ignitor Bracket and Base, Ignitor Bracket to Base)	■	■	■	■
9	Wiring Harness, Control Module to Ignitor	10C405	10C405	10C405	10C405
10	Wiring Harness, Control Module to Controls	10C451	10C451	10C451	10C451
11	Wiring Harness, Control Module to Junction Box	10C452	10C452	10C452	10C452
12	Control Tray (Furnished with Jacket Carton - see Repair Parts Section in Boiler Manual)				

Notes: Weil-McLain Sales Ref. Nos. are found in Weil-McLain Boiler and Controls Repair Parts Book.
 ■ Available at local supply house.



WEIL-McLAIN
 A United Dominion Company

Weil-McLain
 500 Blaine Street
 Michigan City, IN 46360-2388